

**Furniture That Moves**  
by Scale 1:1

scale 1:1



Mobile Markerboard

# NOMAD

Folding Conference Table and Presentation Board  
Sizes Available: 12' x 4', 10' x 4', & 9' x 5'

Scale 1:1

Furniture that Moves  
by Scale 1:1







# NOMAD 12'

Folding Conference Table and Presentation Board

Scale 1:1

Furniture that Moves

by Scale 1:1







# NOMAD 12'

Folding Conference Table and Presentation Board

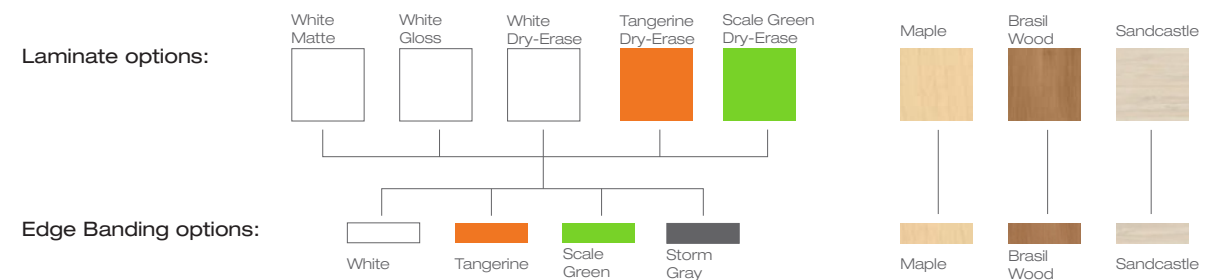

Scale 1:1

Furniture that Moves  
by Scale 1:1



# 1

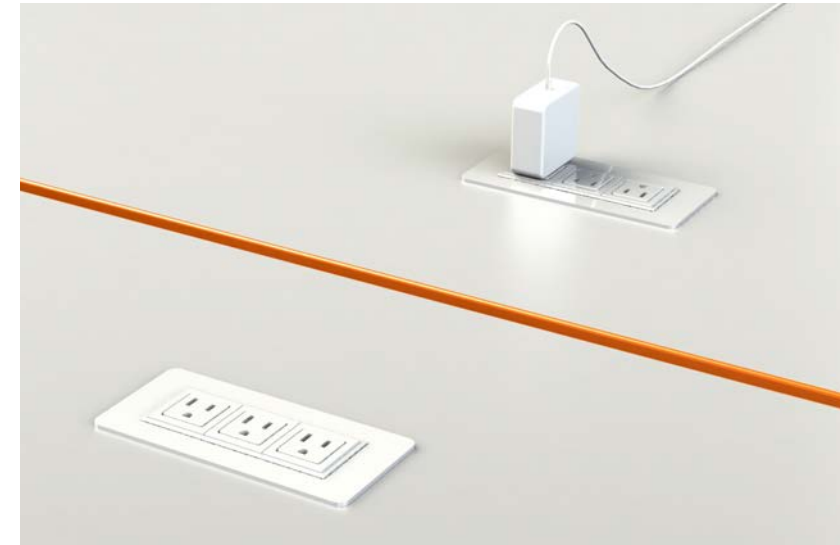

**3-in-1 NOMAD***sport*  
folding conference table | presentation board | ping pong table

scale 1:1

Furniture that Moves  
by Scale 1:1



2

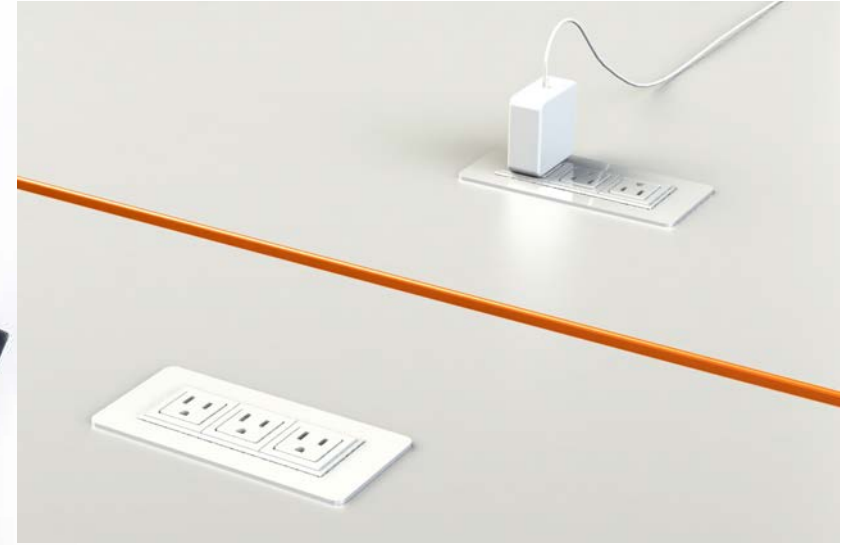

**3-in-1 NOMAD***sport*  
folding conference table | presentation board | ping pong table

Scale 1:1

Furniture that Moves  
by Scale 1:1





# 3

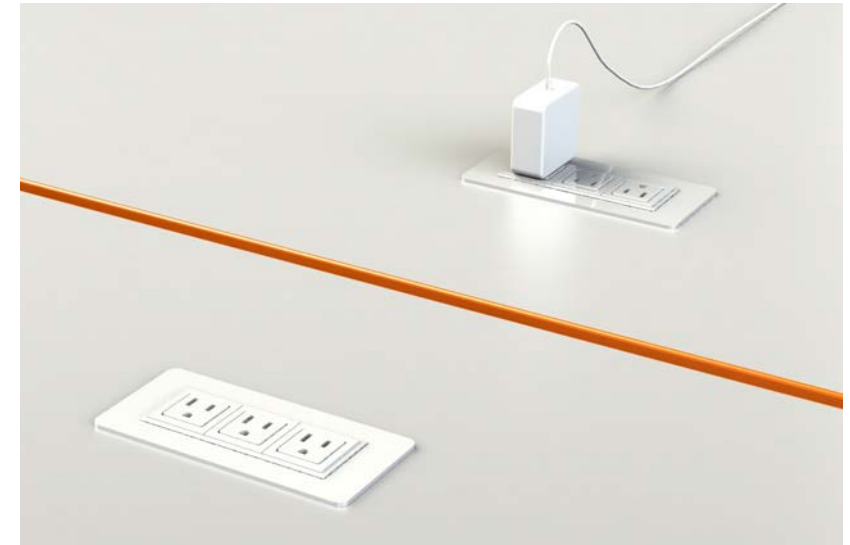

**3-in-1 NOMAD***sport*  
folding conference table | presentation board | ping pong table

# Scale 1:1

Furniture that Moves  
by Scale 1:1







**TouchTable** Flexible space environment  
40" x 40" folding table.

Scale 1:1

Furniture that Moves  
by Scale 1:1





# G-series Tete-a-tete Pairing Stations





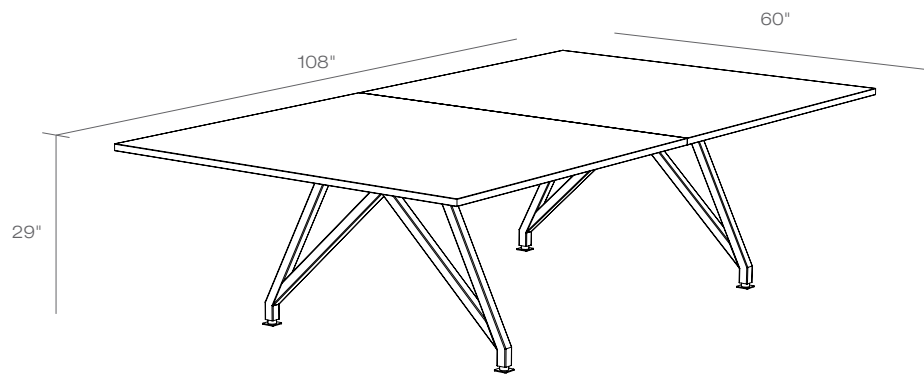

**Power Options**



Pop-Up Power Unit  
SKU: CTPDU-M2X



Flip-top Power Unit  
SKU: CTPDU-E2X

**EYHOV** *sport* Conference

Scale 1:1

Furniture that Moves  
by Scale 1:1



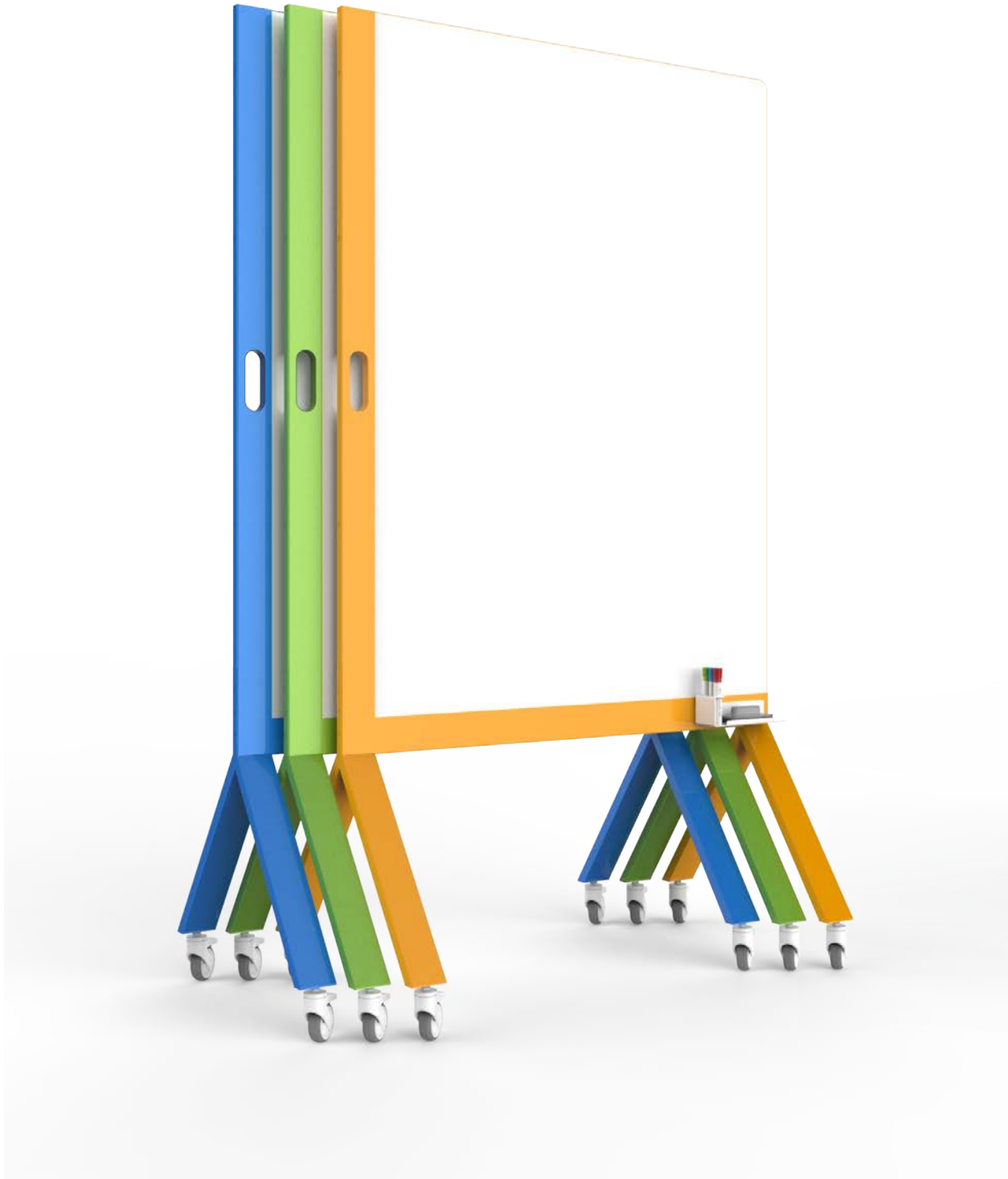

# MARC

Mobile Dry Erase Marker Board

Scale 1:1

Furniture that Moves  
by Scale 1:1



# MARC

Mobile Dry Erase Marker Board

Furniture that Moves  
by Scale 1:1

Scale 1:1





**BOLLA8**  
**POP** Shelving  
 Shelves done at a **POP** of your fingers.



Furniture that Moves  
 by Scale 1:1

Scale 1:1





**BOLLACORE**

**Furniture that Moves**  
by Scale 1:1

**Scale 1:1**



# wiiRise work in motion



**WORK** together



**Multiple Solutions for the Workplace**  
The wiiRise collection offers a complete line of accessories from power/data solutions, to storage and privacy screens, to provide all the comfort to keep your team happy and productive at work.

Scale 1:1

Furniture that Moves  
by Scale 1:1



**RISE** to the occasion

**wiiRise**



Scale 1:1

Furniture that Moves  
by Scale 1:1





# wiiRise 120 Workstations

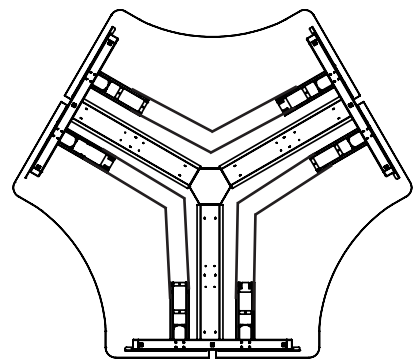

WiiRise is a height-adjustable desk system that combines the healthy benefits of adjustable height workstations with the space efficiency of a benching system. Users are able to independently adjust their work surface from seated height to standing height with push of a button.

Individual Controls in a team work



Your Brand, your Work Culture. Your tailor made work enviroment.

# wiiRise Single Joined Workstations

Scale 1:1

Furniture that Moves  
by Scale 1:1





**wiiRise**

Installation at Virgin Pulse, Providence, RI

Furniture that Moves  
by Scale 1:1

Scale 1:1



# POWER up

## Wire Management Made Simple

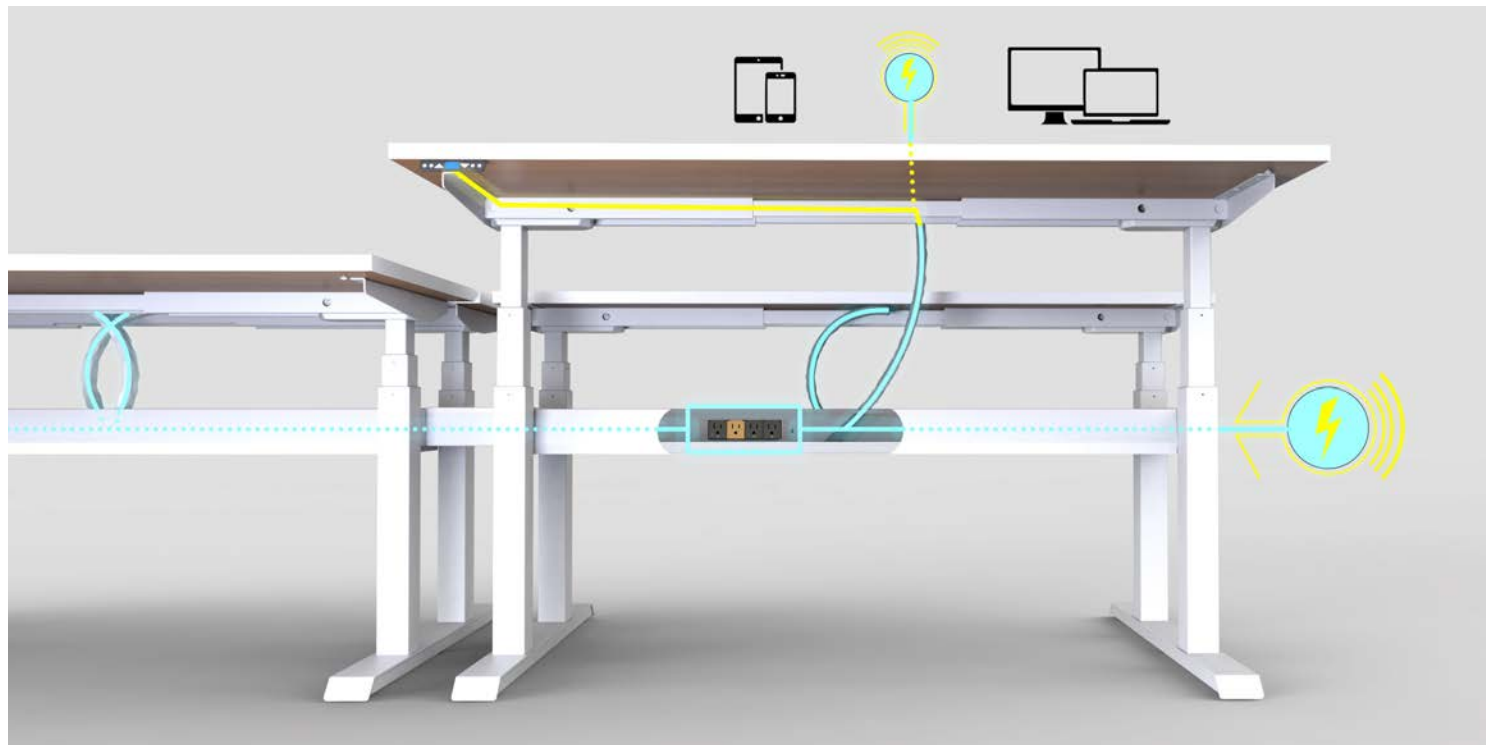

### Infrastructure for Power and Data:

Scale 1:1 offers a full line of power management products that enable seamless power and data distribution throughout the office landscape, including desktop power, USB ports, and monitor arms. For additional options, contact us at [info@scale1to1.com](mailto:info@scale1to1.com).

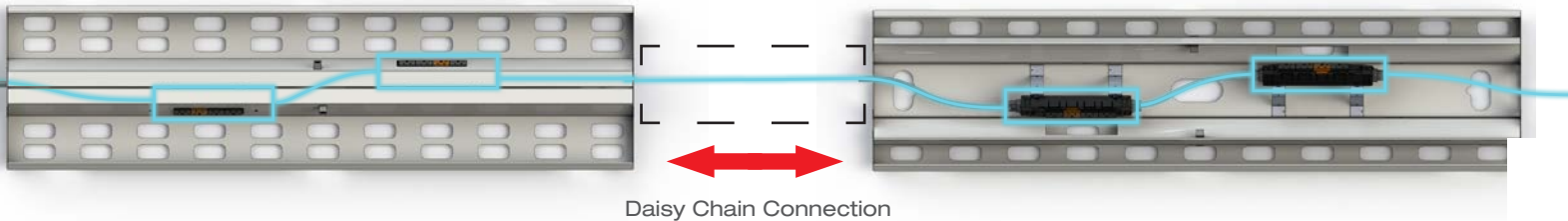

# wiiRise

Technical stuff:

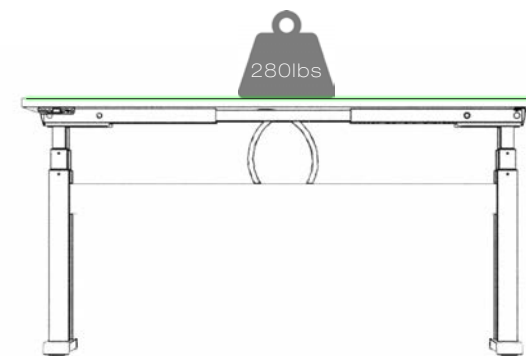
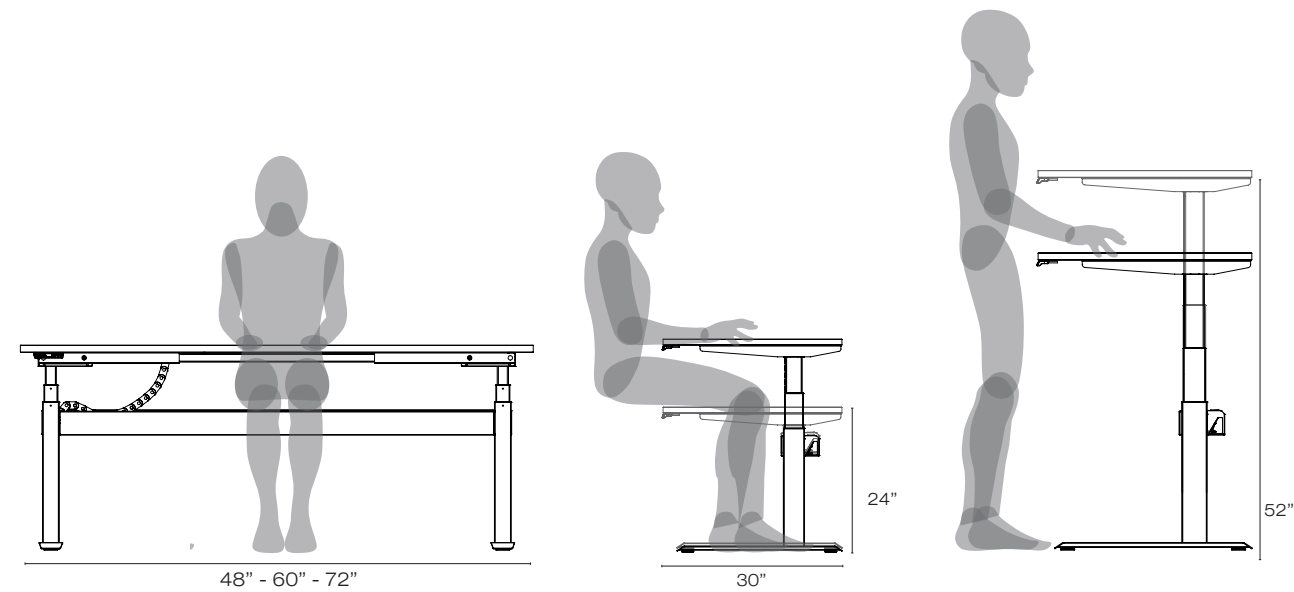

### Technical Reference

Height (Inch)	Min. 24" / Max 49"
Stroke (Inch)	25.5"
Speed (Inch/S)	1.5"
Load Capacity (lbs)	280
Noise db (A)	<50

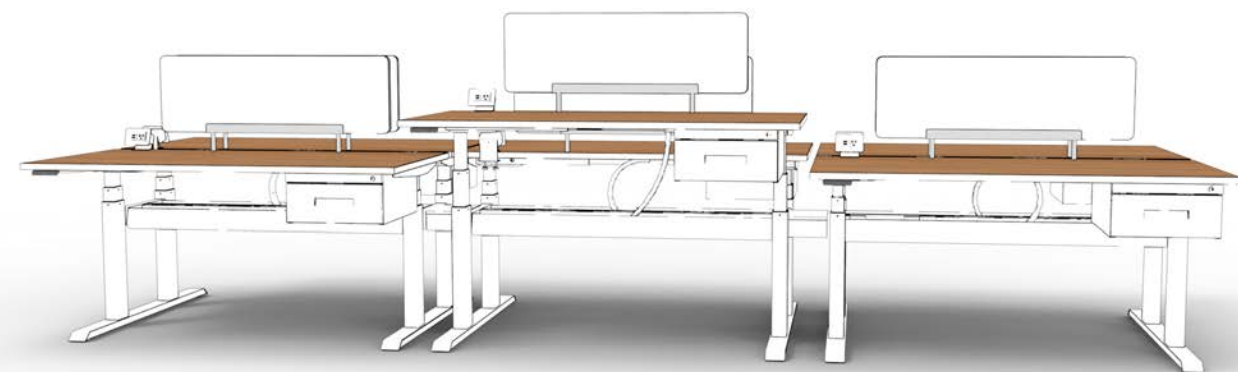

# Scale 1:1

Furniture that Moves

by Scale 1:1





**EYHOV** workstations  
they make you **WANT** to work!

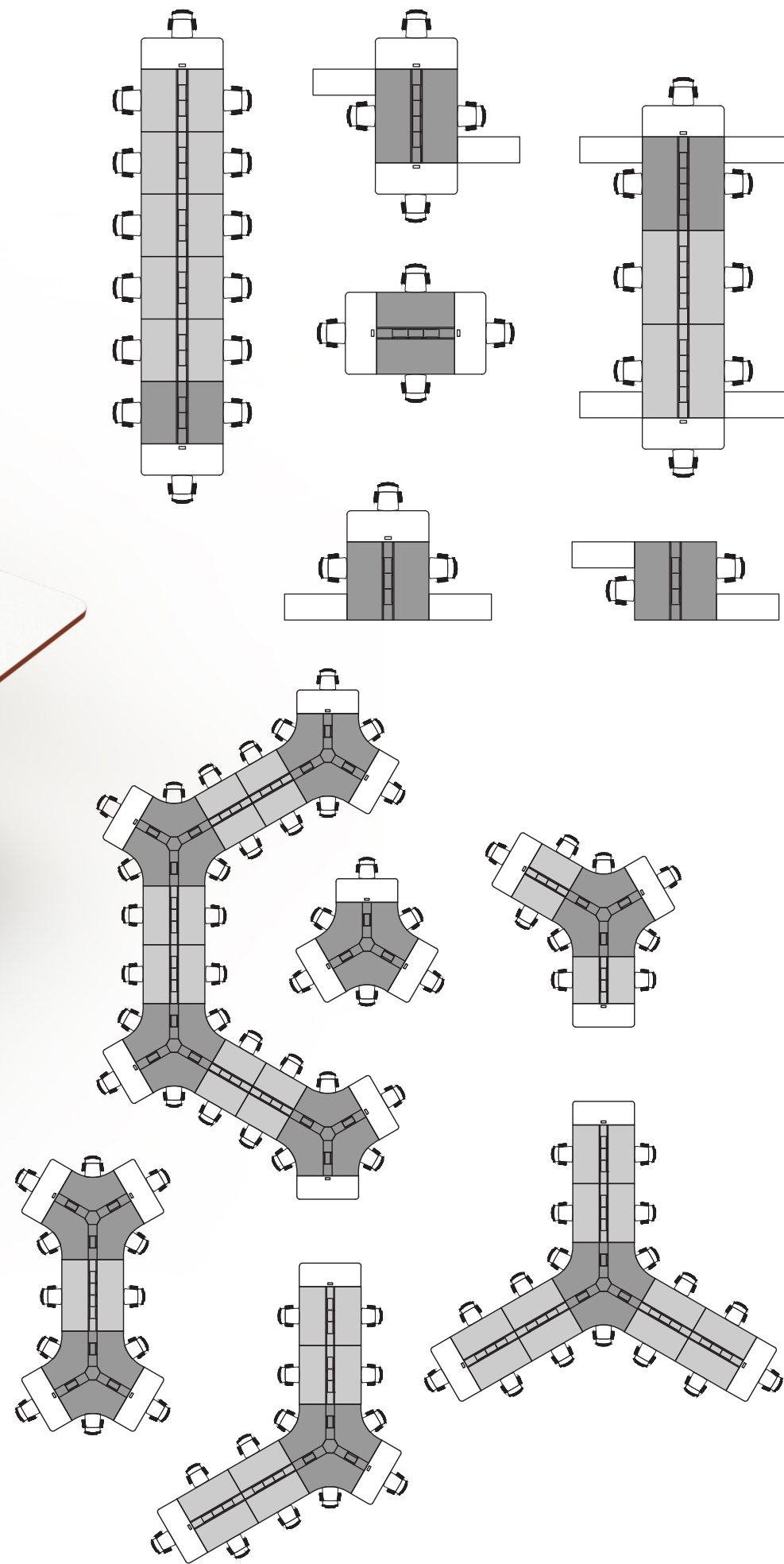

Scale 1:1

Furniture that Moves  
by Scale 1:1



# EYHOV workstations

they make you **WANT** to work!



**EYHOV** RAIL Double



**EYHOV** RAIL 120



**EYHOV** RAIL Single

Scale 1:1

Furniture that Moves  
by Scale 1:1





**EYHOV** RAIL HUB120

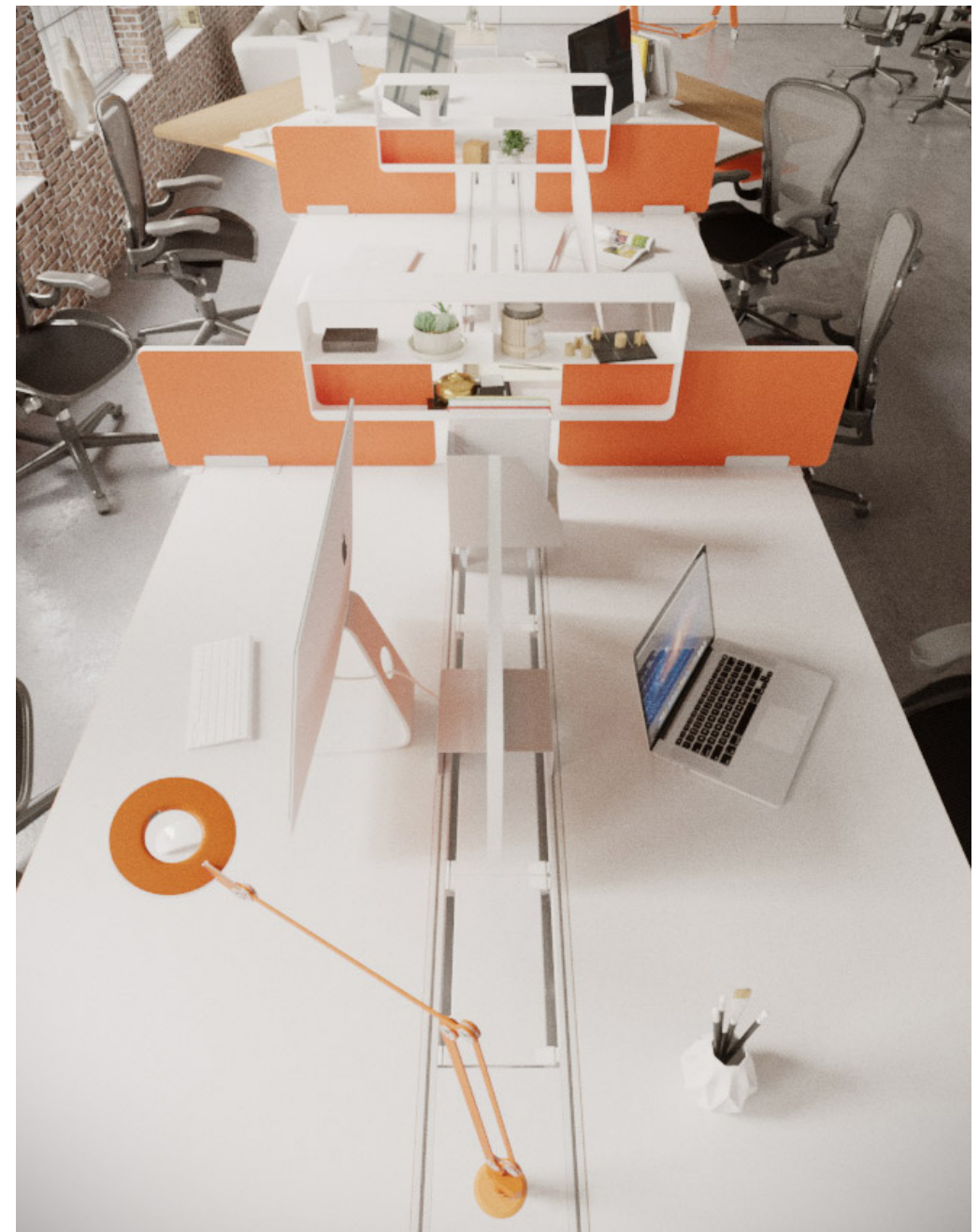

**EYHOV** RAIL Double

**Furniture that Moves**  
by Scale 1:1









**Scale 1:1**

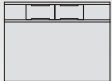

# personalize **EYHOV**

EYHOV accessories offer an array of products to support a broad range of needs. Choose clean and simple workspaces, return shapes, and incorporate more technical tools such as task lighting, monitor arms, and worksurface power. You may also select a variety of privacy screens and desktop organization.



- |   |   |   |   |  |   |   |   |   |
|---|---|---|---|--|---|---|---|---|
|  |  |  |  |  |  |  |  |  |
| 48"<br>Single<br>RS48   | 48"<br>Single Uno Mas<br>RSUM48**   | 60"<br>Single<br>RS60   | 60"<br>Single Uno Mas<br>RSUM60**   | 72"<br>Single<br>RS72  | 72"<br>Single Uno Mas<br>RSUM72**   | Corner Table<br>ECST3636  | End Table<br>EETS36   | Side Table<br>EEST48  |

Scale 1:1

Furniture that Moves

by Scale 1:1



# EYHOV HUB120

EYHOV Hub 120, was designed to integrate effortlessly, easily adapt to changes, and extend planning possibilities for a uniquely functional workspace.

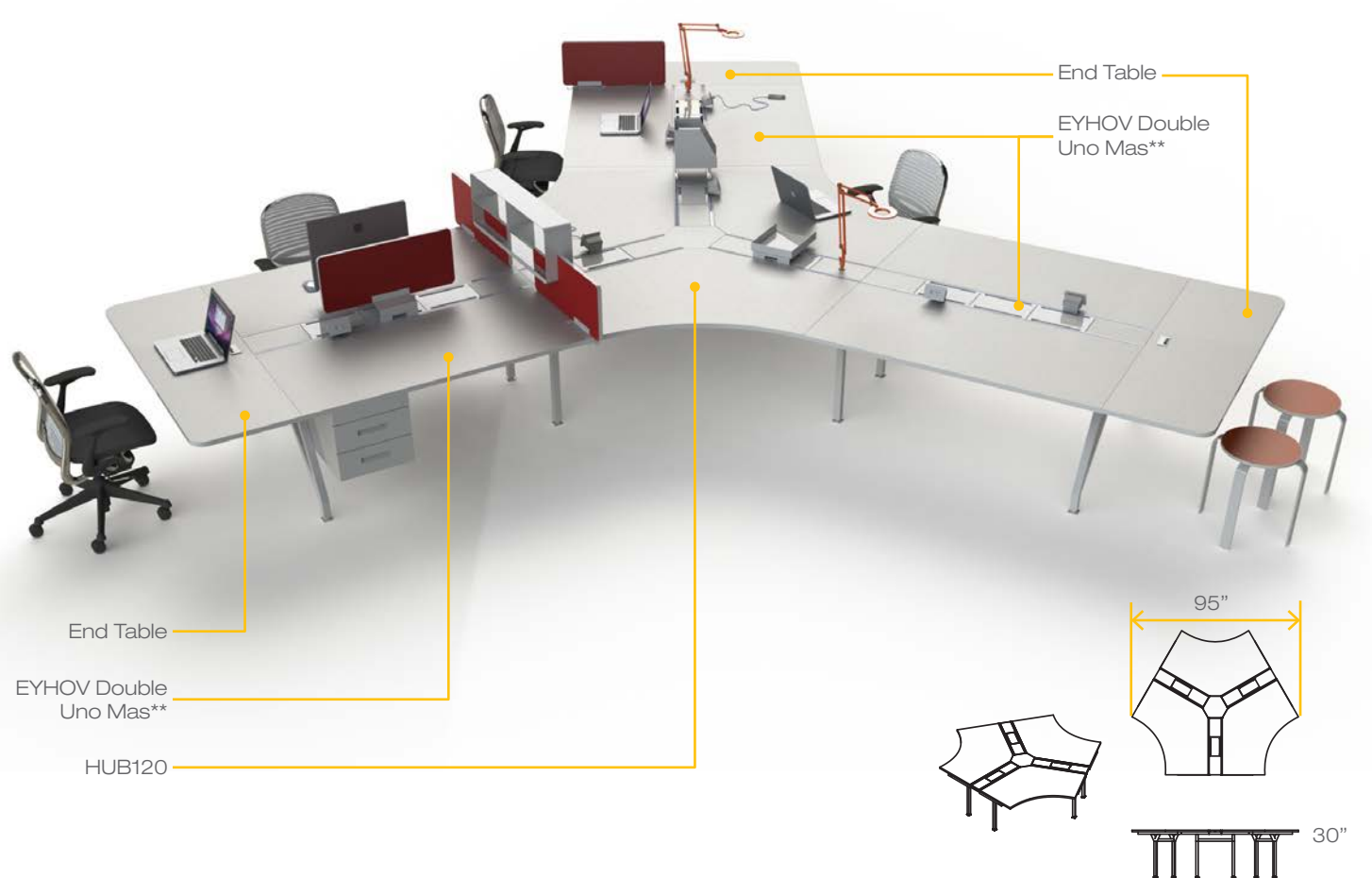
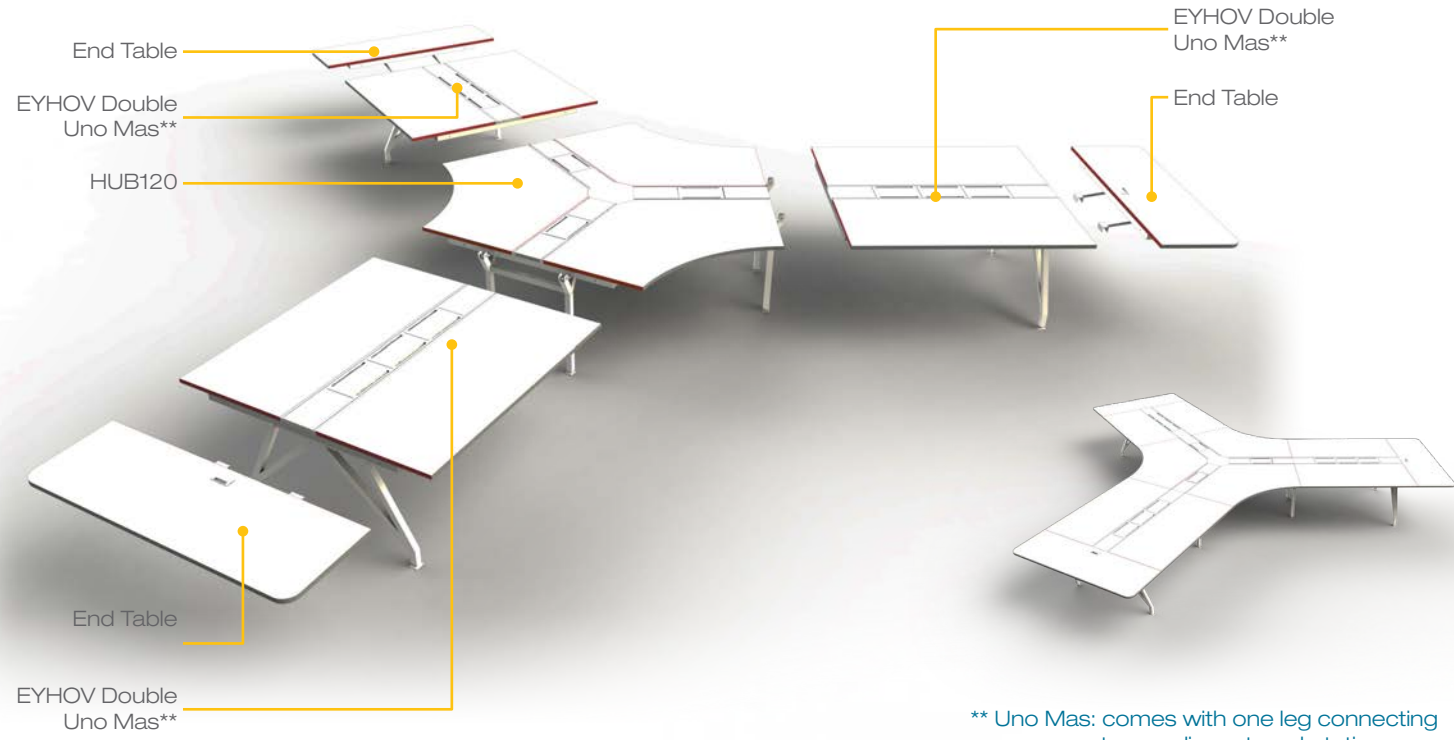

\*\* Uno Mas: comes with one leg connecting to an adjacent workstation

## what you're working with:

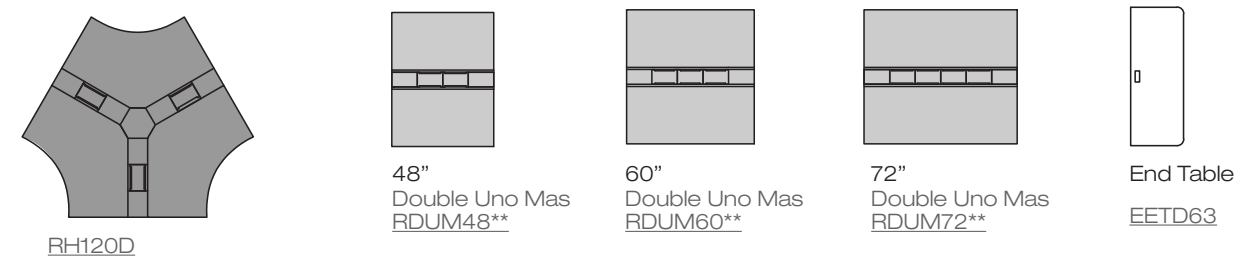

## how you can configure:

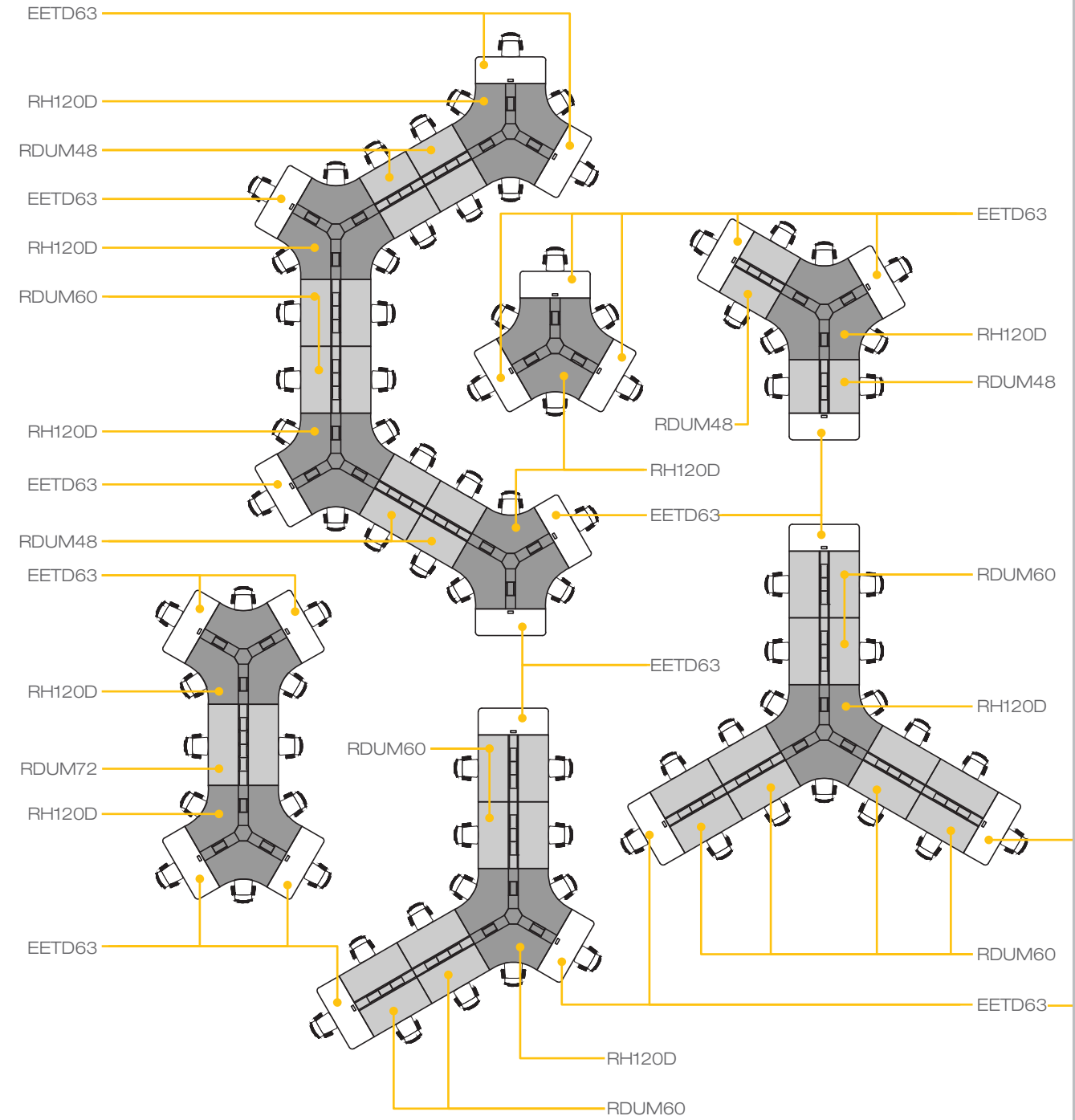

Scale 1:1

Furniture that Moves  
by Scale 1:1



# EYHOVdouble



\*\* Uno Mas: comes with one leg connecting to an adjacent workstation

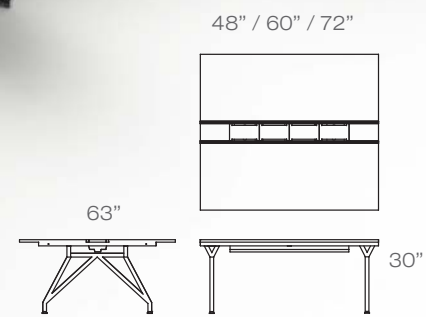

**what you're working with:**

workstations				add-ons			
48\" Double RD48	48\" Double Uno Mas RDUM48**	60\" Double RD60	60\" Double Uno Mas RDUM60**	72\" Double RD72	72\" Double Uno Mas RDUM72**	End Table EETD63	Side Table EEST48

**how you can configure:**

\*\* Uno Mas: comes with one leg connecting to an adjacent workstation

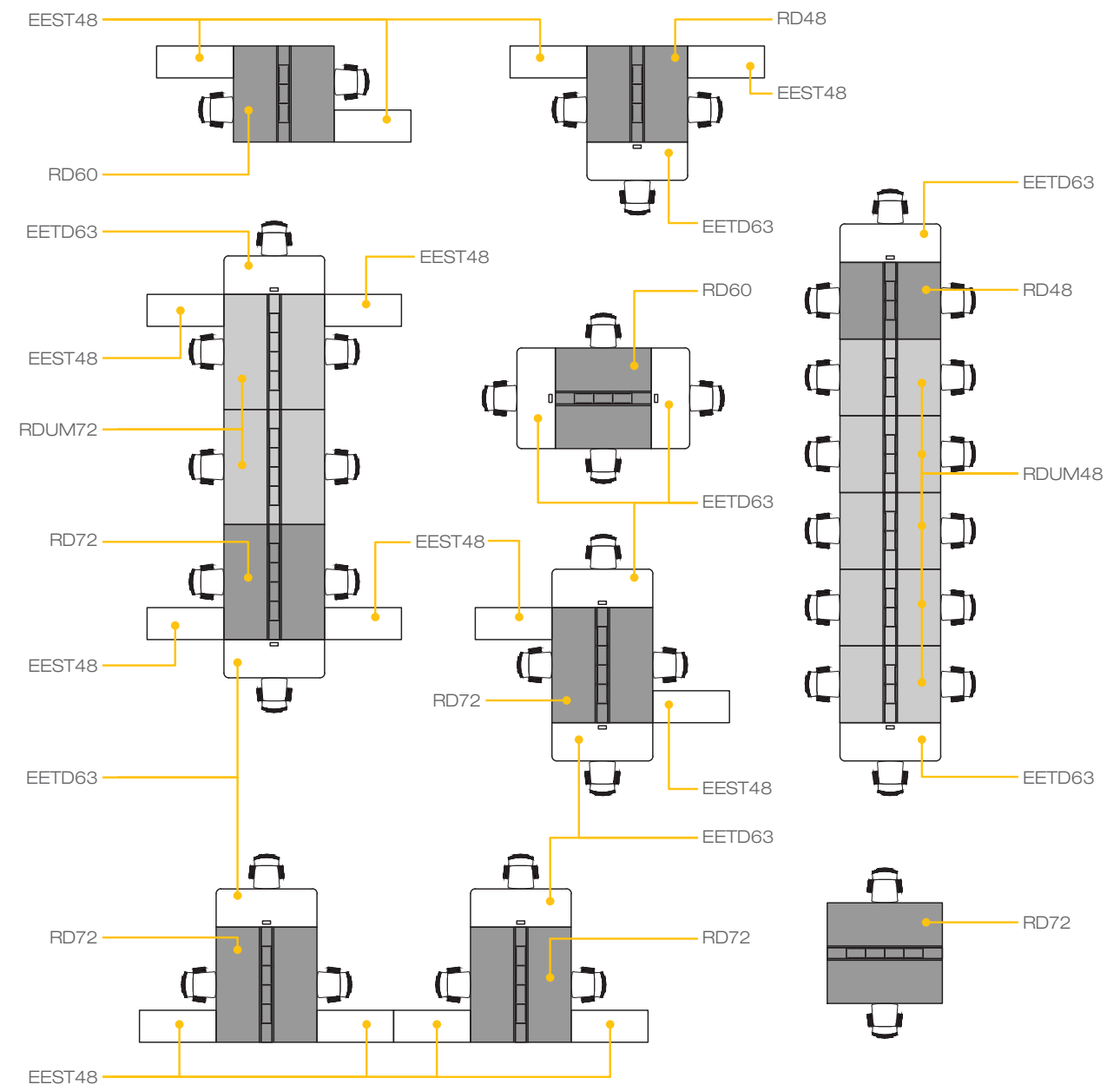



# G-series Double

Connect your **Brand** to  
your **Work** environment



G-Series Workstations. Shown with End table, Side Partitions, Loop Shelf and Nester Lounge

Work, collaborate, recharge  
custom options available.

*nester*  
**DESK LOUNGE**

Scale 1:1

Furniture that Moves

by Scale 1:1



# G-series Single



G-Series Single + End Table

# G-series Double



G-Series Double with End Table +  
G-Series Double Standing Height on Casters

# G-series Double



nester  
DESK LOUNGE



Scale 1:1

Furniture that Moves  
by Scale 1:1



# G-series Double



nester  
DESK LOUNGE

Scale 1:1

Furniture that Moves  
by Scale 1:1



# Training: Flip-Top Tables



Scale 1:1

Furniture that Moves  
by Scale 1:1



# Training: Flip-Top Tables



**Training Table:** The Flip-Top Folding Table is an intelligent, space-saving system. Ideal for conference areas, training rooms, and desks. Daisy-chain power for easy connection.



Scale 1:1

Furniture that Moves

by Scale 1:1

